

Climate effect of bioenergy and agriculture integration based on lowtar gasification of wood chips

Hafthor Ægir Sigurjonsson^{a+}, Brian Elmegaard^a and Lasse Røngaard Clausen^a

^a *Technical University of Denmark, Kongens Lyngby, Denmark, +hafsig@mek.dtu.dk*

Abstract:

To mitigate the increasing pressure on Earth's biosphere through increased concentration of carbon dioxide in the atmosphere, processes in the anthroposphere must change from being fossil- to renewable resource driven. Bioenergy utilization of forest residues can be a step towards achieving that goal. The climate change mitigating effect of different bioenergy scenarios is however not obvious. In recent years, finding the right way to quantify the effect of biogenic carbon emissions associated with bioenergy has gathered attention. This paper analyses the global warming potential of an integrated bioenergy and agricultural system through a polygenerating energy system, producing electricity, district heat and fertile biochar for agricultural soil application. The case analysis is based on utilization of forest residues from a sustainably harvested forest. Quantification of the biogenic global warming potential is included in the analysis, by accounting for both the atmospheric load of biogenic carbon emissions and the carbon captured by forest re-growth. The energy conversion is based on thermal gasification. The gasifier allows changing the carbon conversion fraction, from the conventional maximum energy generation to maximum biochar production. For a 100 year time horizon the biogenic global warming potential varies from 0.65 for maximum energy generation to 0.30 for maximum biochar production. The total carbon footprint per kWh electricity produced decreases towards maximum biochar production, such that in this analysis it outperforms an alternative offshore wind power generation. However, the maximum energy generation scenario just about outperforms an alternative natural gas fuelled power generation. Concluding that for this type of a system, producing more biochar at the expense of energy generation improves its carbon footprint.

Keywords:

Bioenergy, forest residues, gasification, biochar, system integration, biogenic GWP.

1. Introduction

Renewable biomass feedstock for transportation fuels, heat and power generation is generally perceived as a relevant resource to mitigate climate change caused by fossil fuel utilization. However, the effectiveness of bioenergy systems to combat climate change can vary greatly. Depending on, e.g. what type of biomass it is, how it is harvested or collected, distance to end use, and what its utilization will ultimately substitute. Recently, focus on analysing carbon balance within the biomass life cycle has increased.

Soil carbon is estimated to amount to 2157-2293 Pg in the world, of which 684-724 Pg are estimated to be soil organic carbon in the upper 30 cm of soils [1]. However, since the industrial revolution depletion of soil organic carbon has contributed 66-90 Pg to carbon in the atmosphere, this can be compared to the 240-300 Pg contributed by fossil fuel combustion [2]. Additionally, some cultivated soils have lost up to two thirds of their organic carbon, indicating a lot of potential in using the soil carbon pools as carbon sink.

This article presents a consequential Life Cycle Assessment (LCA) of heat, power and fertilizer (gasification ash and biochar) production, utilizing forestry residue (FR) in the TwoStage down draft gasifier [3]. The fertilizer is termed GBC throughout the article. Where the objective is to

determine the value of the integration and compare climate effect and energy efficiency when varying operation in the energy system from maximum energy generation to maximum biochar production.

For the analysis, the total system is modelled by combining the use of energy system software and carbon soil simulation software for both agricultural soils and forestry soils, interconnected with Python. The software used are Dynamic Network Analysis (DNA) [4], C-Tool [5] and Yasso2007 [6] for the energy system, agricultural and forestry soils, respectively.

The novelty of this article is the holistic integrated model of bioenergy and agriculture and the use of a detailed biogenic carbon balance in a case analysis, using the approach of [7-8]. Additionally, the approach of [9] is used for accounting the biochar carbon emission from agricultural soil. Moreover, the energy system is modelled with a comprehensive energy system modelling tool and the carbon conversion in the gasifier is varied, allowing maximum energy efficiency or maximum biochar production in this polygeneration energy system to be simulated.

2. Methods

2.1. Analytical Approach

The analysis is made in a life cycle perspective, based on the Life Cycle Assessment (LCA) methodology over a 100 year time horizon, using the consequential approach [10] and IPCC's global warming potential 100a Life Cycle Impact Assessment (LCIA) method. The system operates to produce electricity and GBC, and the functional unit is 1 kWh electricity produced. This enables comparison with a provision of the service by other feedstock, where the output is 1 kWh electricity produced [11]. The analysis accounts for the upstream impact of removing the residues from the forest and downstream impact of applying GBC to an agricultural field to increase its soil carbon content. The carbon conversion factor (CC) in the gasifier governs the amount emitted from the power plant and the agricultural field, i.e. whether operation is aimed at maximum energy generation or maximum biochar production. The two scenarios are termed High gasifier CC and Low gasifier CC, respectively.

The developed program integrates LCA, energy system, and carbon balance models. The LCA part of the calculation script is done by connecting to the Brightway2 open source LCA program [12] which enables communication with the ecoinvent database for Life Cycle Inventory analysis (LCI) and Life Cycle Impact Assessment [13]. The energy system modelling is done with the Dynamic Network Analysis software developed in the Thermal Energy Section at the Technical University of Denmark. Carbon balance modelling includes a time integrated calculation of the impulse response function and carbon captured by forest re-growth. Along with carbon decay on forest floor and agricultural soil where Yasso07 [6] and C-tool [5] software are used, respectively.

2.2. System Description

The system analysed is an integrated bioenergy and agricultural system, where the waste from the bioenergy system is a resource for the agricultural system. FR is the feedstock for the bioenergy system which generates heat, power and fertilizer. Available FR are divided into above ground FR and below ground FR, the total extraction efficiency is 46%, where 75% of the above ground FR are removed and 0% of the below ground FR. The extracted FR enter the energy system as wood chips which are gasified in the TwoStage gasifier [3] producing product gas and GBC. The GBC is applied to an agricultural field as fertilizer, but the product gas is combusted in a gas engine for heat and power. A simple schematic of the integrated system can be seen in Figure 1.

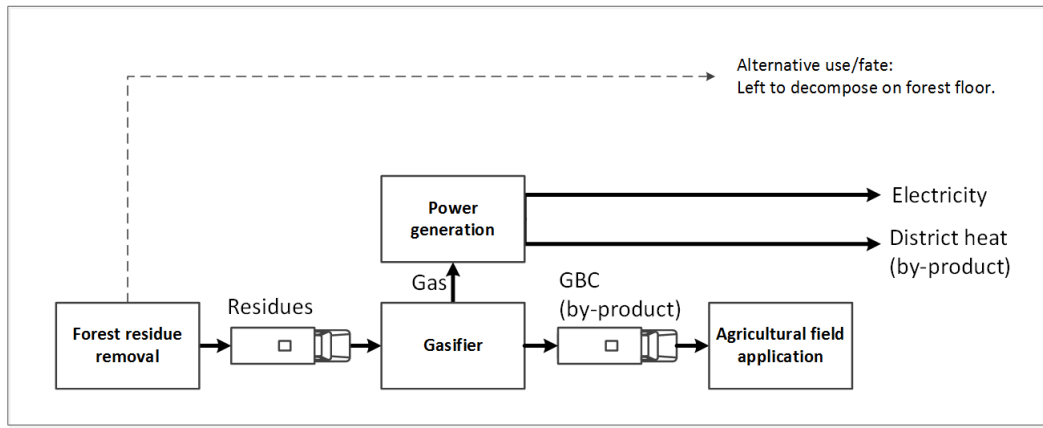

Fig. 1. Schematic of the overall system.

It can be seen in the figure that the total system can be aggregated into four subsystems: forest residue removal, gasifier, power generation and agricultural field application. The forest residue removal LCI is modelled using the strong sustainability concept with the recycled content or cut-off allocation approach [14]. FR are considered as a secondary product of a sustainable harvested forest (logs or stems being the primary product) and using the cut-off allocation approach only the impact associated with the forest residues are accounted for. Other by-products of the system, i.e. district heat in the power generation subsystem and GBC in the gasifier subsystem, are allocated using the system expansion approach.

2.3. Carbon Balance

Carbon balance is made and a biogenic global warming potential GWP_{bio} is calculated for the FR originating CO_2 emissions. This includes carbon emission from product gas combustion in the gas engine, carbon emission from FR on the forest floor, carbon emitted from biochar in the agricultural soil and carbon captured during re-growth. The GWP_{bio} impact factor is based on the integrated radiative forcing difference between biogenic emission and an equivalent fossil carbon pulse emission [7-8]. Carbon will be oxidise to carbon dioxide (CO_2) when entering the atmosphere and all global warming potential (GWP) values are generally benchmarked to CO_2 . Thus knowing the resulting carbon concentration change in the atmosphere over a specific time horizon as a consequence of the production of the functional unit, the GWP_{bio} can be found.

The principles of the method from [8] was used in calculating the GWP_{bio} , but adapted in only account for FR and including the biochar carbon decay.

$$GWP_{bio} = \frac{AGWP_{CO_2, bio}}{AGWP_{CO_2}} = \frac{C_0 \cdot (w \cdot CC \cdot A_T + w \cdot (1 - CC) B_T + (1 - w) \cdot F_T - G_T)}{C_0 \cdot w \cdot A_T} \quad (1)$$

Where $AGWP$ represents the absolute global warming potential or cumulative radiative forcing (CFR), C_0 is the carbon content of the wood chips, w is the FR extraction efficiency (FR carbon extracted / FR carbon available). A_T , B_T and F_T are the time integrated atmospheric CO_2 load of a pulse emission, biochar decay emission and FR decay emission, respectively. G_T is then the time integrated captured load of CO_2 by forest regrowth.

The Bern carbon cycle model [12-13] is used to describe the impulse response function for CO_2 decay in the atmosphere over a specific time horizon, as it is absorbed by the many sinks in Earth's system, e.g. oceans, forests, etc... Modelling the decay of carbon in the FR on the forest floor is done with Yasso07, a dynamic carbon soil model for forest applications [6]. From the result of that

model F_T can be calculated by multiplying the FR decomposition rate with the impulse response function. The decay modelling of GBC was done in a similar way but utilizing the C-tool dynamic carbon soil model for agricultural applications [5]. Like for the FR, the C-tool model calculates the annual decomposition rate which enables B_T calculation. To represent the rate of carbon captured by the re-growth of FR over the time horizon, Schnute model is used [17]. The Schnute model is a versatile growth model based on statistically stable parameters. G_T could then be calculated by multiplying the rate of carbon captured with the impulse response function.

2.4. Energy System Modelling

The energy system is combined with the gasifier and power generation subsystems. It is analysed by modelling its thermodynamic process using the energy system simulation tool Dynamic Network Analysis (DNA) [4]. Figure 2 gives the process flow diagram of the energy system.

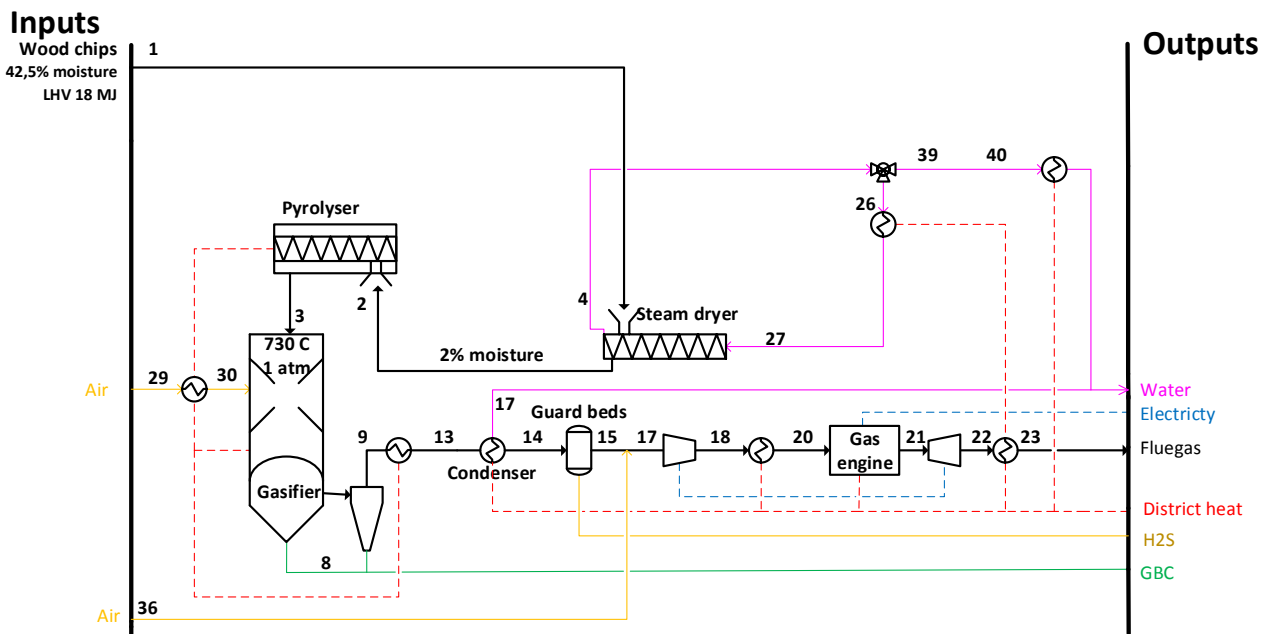

Fig. 2. Process Flow Diagram of the energy system.

Its main components are: The TwoStage gasifier [18], a steam dryer and a gas engine. The FR enters the energy system as wood chips with 42.5% moisture content. They are dried in a steam dryer which operates at 200°C before they enter the two stage pyrolysis and gasification thermochemical converter, i.e. the TwoStage gasifier. The evaporated moisture from the steam dryer is used to generate heat for district heating. After the gasification the hot producer gas is used to fuel the pyrolysis process and to preheat the gasification agent (air), the producer gas is then cooled down to condense out its water content and then cleaned to get rid of H₂S. The gas is then combusted in a turbocharged gas engine to produce electricity for the national grid and district heating for the local community.

The TwoStage gasifier has a separate pyrolysis and gasification unit and a high temperature tar cracking zone in-between. This allows the gasification producer gas to have very low tar content, which enables it to be utilized in a gas engine [3]. The gasifier component model in DNA was developed for [19]. As mentioned in Section 2.1, one of the main parts of the analysis is to show the difference in the results when the gasifier is operated with different levels of carbon conversion. This is included in the energy system model and the system is simulated with a large range of CC values. Key parameters of the energy system, for the two scenarios are given in Table 1.

Table 1. Key inputs to the energy system model.

Key value	Unit	High gasifier CC	Low gasifier CC
Gasifier carbon conversion	-	0.99	0.60
Gasification temperature	°C	730	730
Moisture content after dryer	%	2.0	2.0
Component pressure drops	bar	0.0	0.0
Temperature inside dryer	°C	200	200
Gas engine power efficiency	%	38	38
Air–fuel equivalence ratio	-	2	2

The performance of the energy system is measured by the electrical efficiency, fuel utilization and exergetic efficiency of the whole unit. Electrical efficiency is based on the first law of thermodynamics and is calculated by dividing the net electricity generated with the energy content of the input. Similarly, the fuel utilization is also based on the first law of thermodynamics and is calculated by dividing the net energy generated (heat and power) with the energy content of the wood chips. However, the exergetic efficiency is a concept of the second law of thermodynamics and is calculated by dividing the systems product exergy value with the exergy value of its fuel [20]. In this system the fuel is defined as the wood chips input and the product is defined as the net electricity and heat generated, along with the GBC produced. But, exergetic efficiency of an energy system most often discounts the ash and char by-products as loss or destroyed exergy. For reference the exergetic efficiency of the energy system discounting the GBC is included. It should be mentioned that only the chemical exergy of GBC is included in the efficiency calculation and the physical exergy is assumed to be dissipated to the environment.

2.5. Life Cycle Assessment

The carbon balance calculation and the energy system modelling are tied together in LCA. They are joined by other elements of the life cycle inventory (LCI), e.g. extraction and transport of the FR, and the transport and application of the GBC to the agricultural field. Along with the assumed change in fertilization requirements of the agricultural field by the potassium (K) and phosphorus (P) input from GBC. The mineral fertilizer value of these elements in GBC are assumed to be 100% as done in [15-16] for GBC from a low temperature gasification. Along with the input of phosphorus and potassium in the ash, the nitrogen input is expected to be affected as well. However, not enough data could be collected to include that in the analysis.

As the assessment is consequential, the substituted marginal needs to be found for K and P fertilizers, and the district heating. For the P and K fertilizers the marginal substituted products are diammonium phosphate and potassium chloride fertilizers as done in [23] which is based on [18-19], respectively. The heat producing technology substituted is assumed to be the heat generated part of a decentralised natural gas fired combined heat and power plant.

3. Results

3.1. Carbon Balance

The cumulated decomposition curves of the FR and GBC is given in Figure 3, along with the growth rate and cumulated growth of FR. The FR decomposition curve is split into above ground and below ground FR curves.

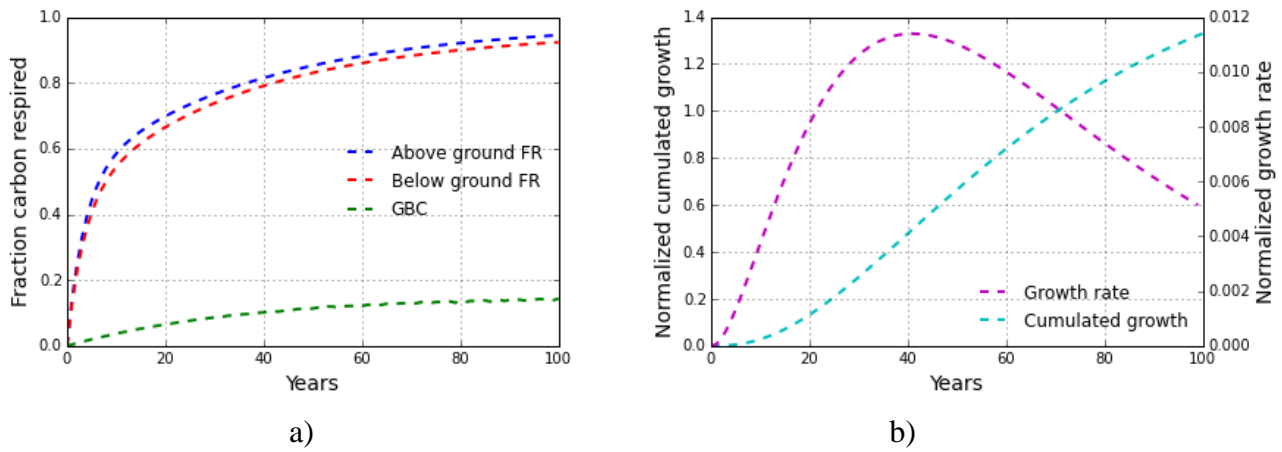

Fig. 3. Rate of carbon emission and capture: a) Simulated carbon respiration, b) simulated growth rate and cumulated growth.

It can be seen in Figure 3 a) that GBC carbon respire very slowly compared to FR. This should benefit the Low gasification CC scenario as most of the carbon applied to the agricultural field can be considered to be sequestered in the soil in a 100 year timeframe. Figure 3 b) provides an insight into how rapidly after emitting biogenic carbon it is captured again with the 100 year rotating sustainable forestry.

The atmospheric CO_2 loads over the time horizon for each part of the GWP_{bio} formula is given in Figure 4, along with the $\text{AGWP}_{\text{bio},\text{CO}_2}$ or CRF at each stage of the time horizon for the two scenarios and the $\text{AGWP}_{\text{CO}_2}$ reference, which its integration represent the numerator and denominator in (1), respectively.

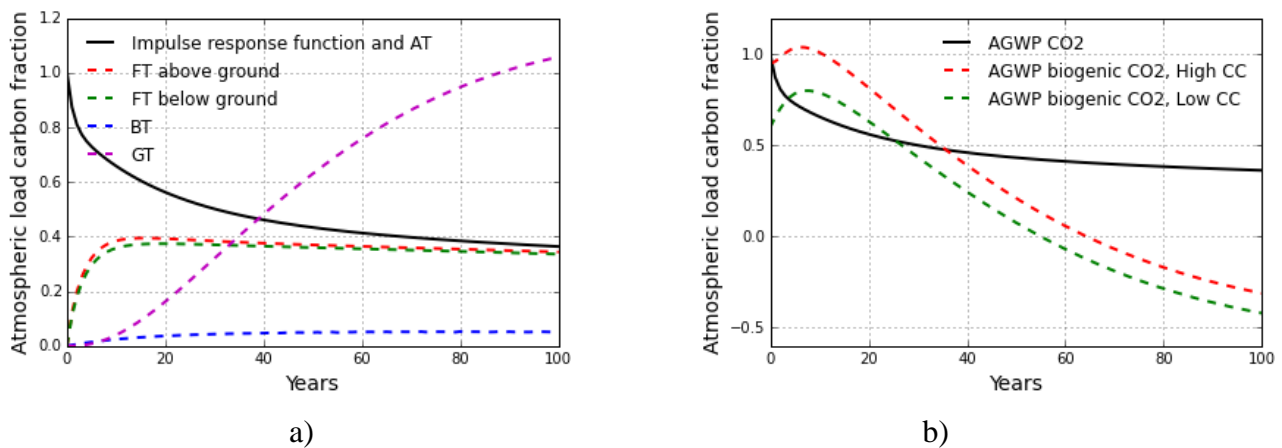

Fig. 4. Atmospheric CO_2 loads: a) Individual parts of (1), b) Total loads of the two scenarios and fossil CO_2 as a reference.

Figure 4 a) give an insight into the relative importance of each part of the carbon balance. The difference between the two scenarios is the distribution between A_T and B_T . The High gasification CC scenario has high A_T and low B_T , but the Low gasification CC scenario maximizes the potential of the B_T part of the equation (lowering A_T as a consequence) which decreases its $\text{AGWP}_{\text{bio},\text{CO}_2}$. This effect can be observed in Figure 4 b). The resulting GWP_{bio} for the High and Low gasification CC scenarios are 0.65 and 0.30, respectively.

3.2. Energy System Modelling

The values presented here are given in rates, i.e. mass flow, power, etc... The modelling assumed that 9000 tonnes of wet wood chips would enter the system and be used over the whole year with the capacity factor of 0.9. Table 2 displays the main outputs of the energy system simulation, other properties of the energy system can be found in Tables A1 and A2 in Appendix for the two scenarios. Figure 5 displays these resulting efficiencies for a range of CC values, i.e. from 0.60 to 0.99.

Table 2. Main outputs of the energy system simulation.

Key values	Unit	High gasifier CC	Low gasifier CC
Gasifier cold gas efficiency	%	93.4	60.6
Net power production	kW	1055	628
Net district heat production	kW	1576	978
GBC output flow	kg/s	0.0025	0.0373

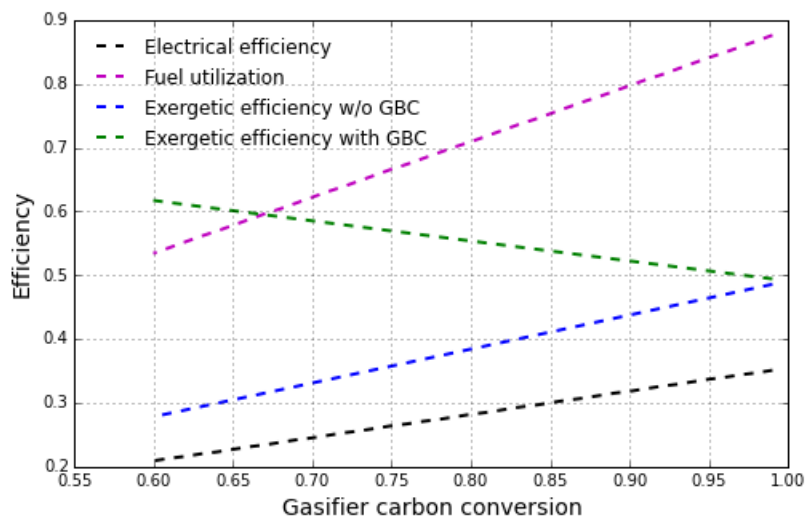

Fig. 5. Efficiencies of the energy system of a range of CC values.

It can be seen in the figure that the electrical efficiency, fuel utilization and exgetic efficiency where GBC is a loss of the system, declines as the CC is decrease from maximum energy generation to maximum GBC production. However, if the energy system approached as a polygeneration system, producing electricity, heat for district heating and GBC as a high carbon fertilizer for agricultural soils the exergetic efficiency increases with decreased CC.

3.3. Life Cycle Assessment

The LCI results includes the main parts of the system, i.e. residue recovery and chipping, transportation to and from the energy system, P and K value of the GBC, and carbon balance disaggregated to show what is allocated to power plant emissions, carbon from forest floor removal and carbon in agricultural soil sequestration. Since the functional unit is kWh electricity produced the LCI data is given in per kWh also. LCI results are presented in Table 3.

It can be seen in Table 3 that the LCI for the two scenarios changes with CC. The Low gasification CC scenario requires more input to produce the same amount of electricity as the High gasification CC scenario, which subsequently affects other parts of the system. Figure 6. displays the LCIA results for the overall system.

Table 3. Life Cycle Inventory per kWh electricity produced.

Key values	Unit	High gasifier CC	Low gasifier CC
Mass input	kg	1.06	1.65
Misc. energy system electricity use	kWh	0.13	0.22
Residue recovery	MJ	0.12	0.18
Chipping	MJ	0.05	0.07
Transport	tonne × km	0.054	0.092
District heat produced	MJ	4.75	4.59
GBC output flow	kg	0.0085	0.1943

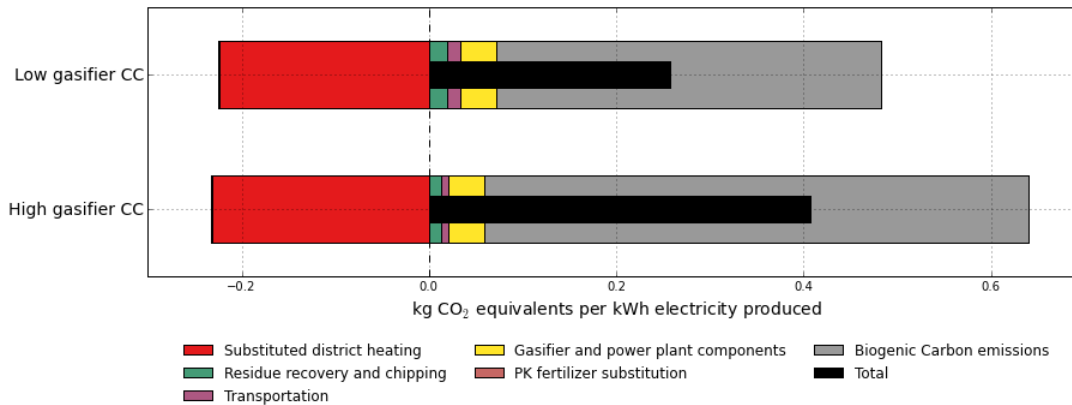

Fig. 6. IPCC GWP 100a total Life Cycle Impact Assessment results.

It can be seen in the figure that the main contributions to the results are from the energy technology substitution and biogenic carbon emissions. Also, it shows that lowering the carbon conversion in the gasifier decreases the carbon footprint of the FR fuelled power generation.

To put the results of Figure 6 into context, a comparison is made with LCA results from alternative power generation from the ecoinvent database [13]. These alternatives are fuelled with coal, natural gas and wind. The coal and natural gas fuelled production co-generate heat for district heating. To justify the comparison, this heat substitutes the same district heating as the two scenarios did. Additionally, forest floor emissions are included in the LCA of the alternatives, as it is assumed that the FR used in the two scenarios are now allowed to decompose on the forest floor. Figure 7 displays the IPCC GWP 100a LCIA for producing 1 kWh of electricity from the two scenarios and the alternatives.

It can be observed in Figure 7 a) and b) that the two scenarios perform better than the fossil fuelled alternatives. However, the High gasifier CC scenario just marginally outperforms natural gas fuelled production. Conversely, the Low gasifier CC scenario marginally outperforms offshore wind power generation.

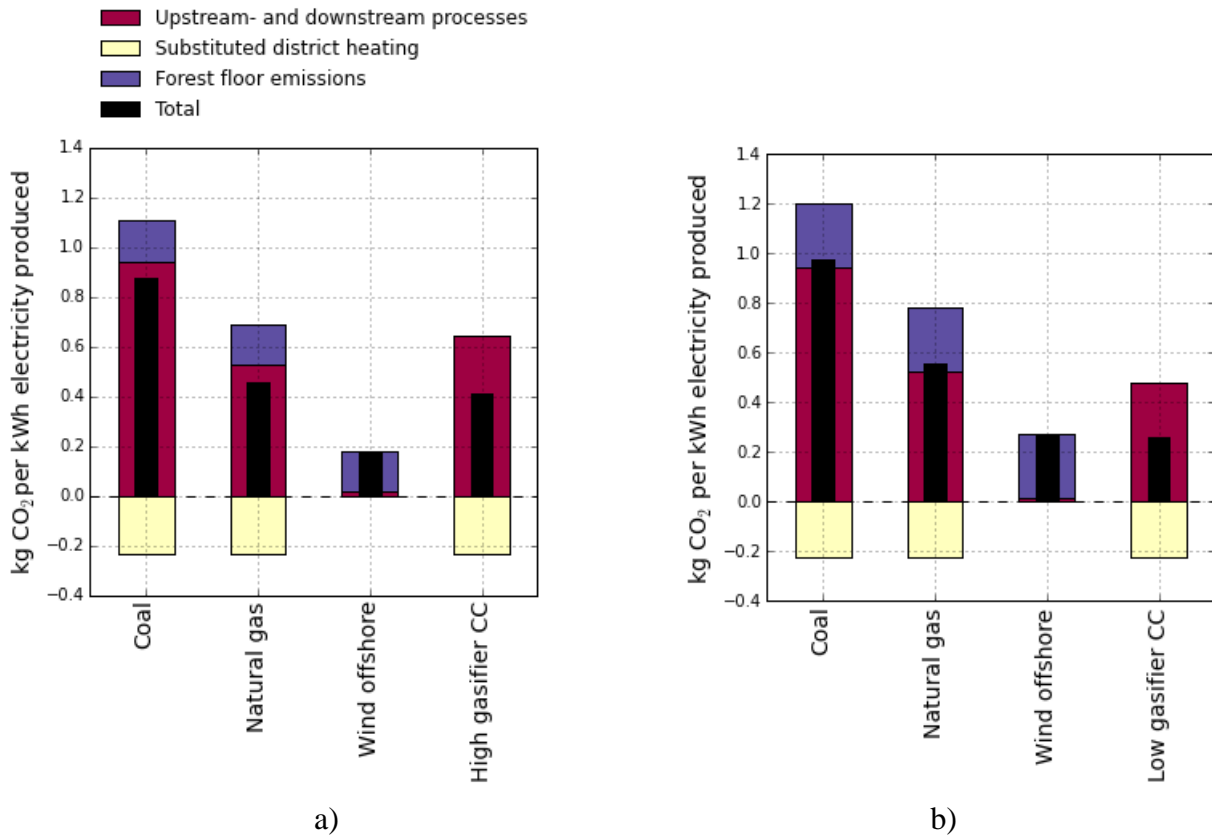

Fig. 7 Comparison of LCIA per kWh for scenarios and from other resources: a) High gasification CC scenario, b) Low gasification CC scenario.

4. Discussion

When observing the results of the two scenarios it is clear that the effect of the GWP_{bio} is important. However, what is striking is that increasing the carbon in the GBC at the cost of the energy efficiency of the gasifier has positive effect the carbon footprint of the system. Also, from the results of the energy system simulation, the exergetic efficiency when including the GBC as a product showed an increase with decreased energy efficiency. This is important as there is increasing focus on treating “waste” as a product of a system. These results indicate that designing processes in that way could result in a better performing systems both in terms of environmental and exergetic performance.

The change in GWP_{bio} with CC is noteworthy. The cause is the change in the first year pulse emitted CO₂ per mass input to the energy system when CC is lowered. Almost all of the carbon input to the energy system is pulse emitted at the beginning of the timeframe in the high gasifier CC scenario, but a large part of it is slowly decomposed in the agricultural system for the low gasifier CC scenario. Based on these results it looks like pyrolysis could be an interesting thermochemical conversion process for biomass in terms of carbon footprint when accounting for the positive effects of the biochar.

As indicated in Section 2.5 the effect on the nitrogen balance of the agricultural soil by the input of GBC is not included. However, it has been observed that there are positive effects on the agricultural soil's water retention with increased biochar input [26]. It is also expected that nitrogen will build up as carbon is built up in the soil [27]. Both of these effects would contribute in favour of returning the GBC to an agricultural field and decrease the CC.

In Figure 7 a notable comparison was made between the scenarios and alternative energy systems. In that comparative analysis the alternatives were credited the FR forest floor emissions as they are left unutilized. The scenarios are modelled by taking into account all above- and below ground FR, but with FR extraction efficiency of 46%. It is expected that the performance of the scenarios will be better with increased FR extraction efficiency and worse with decreased efficiency. It would be interesting to expand the analysis to include the primary production of the sustainably harvested forest in a dedicated forestry bioenergy system.

In this analysis only LCIA associated with climate change was observed. However, a lot of different environmental impacts could (and should) be analysed to further assess the value of a decreased CC in a gasifier. It would also be interesting to do an economic analysis of such system integration, as it could be that lowering the CC would increase the value of the fertile GBC and thus mitigate the revenue losses from decreased efficiency. Additionally, a gasifier with a low CC could be smaller and is therefore expected to be cheaper than a gasifier with a high CC.

5. Conclusion

The article has presented a carbon footprint LCA study of an integrated bioenergy and agriculture system using wood chips from forest residues. The wood chips are used in thermal gasification to produce fuel for the CHP plant, while the GBC is applied to an agricultural soil containing biochar and nutrients.

Based on the results of the study, the main conclusions are that:

1. Utilization of forest residues, by removing them from the forest floor and presenting them as wood chips to an energy efficient energy system barely hold the comparison with fossil fuel energy systems. It does perform better than a coal based energy system, but is only marginally superior to a natural gas energy system.
2. Decreasing the carbon conversion of the gasifier, and thus allowing more carbon in the GBC, at the expense of the gasifier efficiency, improves the GWP_{bio} of the system. Such a system can even outperform offshore wind energy system in a carbon based LCA. However, those results depend on the FR extraction efficiency and the allocation between the primary and secondary production of the sustainably harvested forest.

These conclusions underline the importance of considering the GBC from a gasification system as an important fertilizer and soil amendment product. However, taking into account the possible changes in the soil's water retention, the positive effect on the environmental impact can possibly be demonstrated as even greater.

Acknowledgments

This study was funded by the Villum foundation.

References

- [1] N. H. Batjes, "Total carbon and nitrogen in the soils of the world," *Eur. J. Soil Sci.*, vol. 65, no. 1, pp. 10–21, Jan. 2014.
- [2] R. Lal, "Soil carbon sequestration to mitigate climate change," *Geoderma*, vol. 123, no. 1–2, pp. 1–22, Nov. 2004.
- [3] J. Ahrenfeldt, T. P. Thomsen, U. Henriksen, and L. R. Clausen, "Biomass gasification cogeneration – A review of state of the art technology and near future perspectives," *Appl. Therm. Eng.*, vol. 50, no. 2, pp. 1407–1417, Feb. 2013.
- [4] B. Elmegaard and N. Houbak, "DNA – A General Energy System Simulation Tool," *Proc. SIMS 2005*, pp. 43–52, 2005.
- [5] B. M. Petersen, J. E. Olesen, and T. Heidmann, "A flexible tool for simulation of soil carbon turnover," *Ecol. Modell.*, vol. 151, no. 1, pp. 1–14, May 2002.
- [6] J. Liski, T. Palosuo, M. Peltoniemi, and R. Sievänen, "Carbon and decomposition model Yasso for forest soils," *Ecol. Modell.*, vol. 189, no. 1–2, pp. 168–182, Nov. 2005.
- [7] F. Cherubini, A. H. Strømman, and E. Hertwich, "Effects of boreal forest management practices on the climate impact of CO₂ emissions from bioenergy," *Ecol. Modell.*, vol. 223, no. 1, pp. 59–66, Dec. 2011.
- [8] G. Guest, F. Cherubini, and A. H. Strømman, "The role of forest residues in the accounting for the global warming potential of bioenergy," *GCB Bioenergy*, vol. 5, no. 4, pp. 459–466, Jul. 2013.
- [9] B. M. Petersen, M. T. Knudsen, J. E. Hermansen, and N. Halberg, "An approach to include soil carbon changes in life cycle assessments," *J. Clean. Prod.*, vol. 52, pp. 217–224, Aug. 2013.
- [10] M. Brander, R. Tipper, C. Hutchison, and G. Davis, "Consequential and attributional approaches to LCA: a Guide to policy makers with specific reference to greenhouse gas LCA of biofuels," *Econom. Press*, no. April, pp. 1–14, 2008.
- [11] F. Cherubini and A. H. Strømman, "Life cycle assessment of bioenergy systems: state of the art and future challenges," *Bioresour. Technol.*, vol. 102, no. 2, pp. 437–51, Jan. 2011.
- [12] C. Mutel, "Brightway2." 2015.
- [13] B. P. Weidema, C. Bauer, R. Hirschler, C. Mutel, T. Nemecek, J. Reinhard, C. O. Vadenbo, and G. Wernet, "The ecoinvent database: Overview and methodology, Data quality guideline for the database version 3." 2013.
- [14] R. Frischknecht, "LCI modelling approaches applied on recycling of materials in view of environmental sustainability, risk perception and eco-efficiency," *Int. J. Life Cycle Assess.*, vol. 15, no. 7, pp. 666–671, Jun. 2010.
- [15] F. JOOS, M. BRUNO, R. FINK, U. SIEGENTHALER, T. F. STOCKER, C. LE QUERE, and J. L. SARMIENTO, "An efficient and accurate representation of complex oceanic and

biospheric models of anthropogenic carbon uptake,” *Tellus B*, vol. 48, no. 3, pp. 397–417, Jul. 1996.

- [16] F. Joos, I. C. Prentice, S. Sitch, R. Meyer, G. Hooss, G.-K. Plattner, S. Gerber, and K. Hasselmann, “Global warming feedbacks on terrestrial carbon uptake under the Intergovernmental Panel on Climate Change (IPCC) Emission Scenarios,” *Global Biogeochem. Cycles*, vol. 15, no. 4, pp. 891–907, Dec. 2001.
- [17] J. Schnute, “A Versatile Growth Model with Statistically Stable Parameters,” *Can. J. Fish. Aquat. Sci.*, vol. 38, no. 9, pp. 1128–1140, Sep. 1981.
- [18] B. Gøbel, C. Hindsgaul, U. B. Henriksen, J. Ahrenfeldt, F. Fock, N. Houbak, and E. B. Qvale, “High Performance Gasification with the Two-Stage Gasifier,” in *Proceedings of the 12. European Biomass Conference. ETA-Florence & WIP-Munich*, 2002, pp. 389–395.
- [19] L. R. Clausen, B. Elmegaard, J. Ahrenfeldt, and U. Henriksen, “Thermodynamic analysis of small-scale dimethyl ether (DME) and methanol plants based on the efficient two-stage gasifier,” *Energy*, vol. 36, no. 10, pp. 5805–5814, Oct. 2011.
- [20] A. Bejan, G. Tsatsaronis, and M. J. Moran, *Thermal Design and Optimization*. John Wiley & Sons, 1996.
- [21] T. L. T. Nguyen, J. E. Hermansen, and R. G. Nielsen, “Environmental assessment of gasification technology for biomass conversion to energy in comparison with other alternatives: the case of wheat straw,” *J. Clean. Prod.*, vol. 53, pp. 138–148, Aug. 2013.
- [22] T. L. T. Nguyen, J. E. Hermansen, and L. Mogensen, “Environmental performance of crop residues as an energy source for electricity production: The case of wheat straw in Denmark,” *Appl. Energy*, vol. 104, pp. 633–641, Apr. 2013.
- [23] L. Hamelin, M. Wesnæs, H. Wenzel, and B. M. Petersen, “Environmental consequences of future biogas technologies based on separated slurry,” *Environ. Sci. Technol.*, vol. 45, no. 13, pp. 5869–77, Jul. 2011.
- [24] F. Tenkorang and J. Lowenberg-DeBoer, “Forecasting long-term global fertilizer demand,” *Nutr. Cycl. Agroecosystems*, vol. 83, no. 3, pp. 233–247, Oct. 2008.
- [25] FOOD & AGRICULTURE ORGANIZATION OF THE UNITED NATIONS, “Current world fertilizer trends and outlook to 2013,” 2009.
- [26] V. Hansen, D. Müller-Stöver, J. Ahrenfeldt, J. K. Holm, U. B. Henriksen, and H. Hauggaard-Nielsen, “Gasification biochar as a valuable by-product for carbon sequestration and soil amendment,” *Biomass and Bioenergy*, vol. 72, pp. 300–308, Jan. 2015.
- [27] B. M. Petersen, L. S. Jensen, S. Hansen, A. Pedersen, T. M. Henriksen, P. Sørensen, I. Trinsoutrot-Gattin, and J. Berntsen, “CN-SIM: a model for the turnover of soil organic matter. II. Short-term carbon and nitrogen development,” *Soil Biol. Biochem.*, vol. 37, no. 2, pp. 375–393, Feb. 2005.

Appendix A

Table A1. Flow properties at each stage of the energy system. High gasification CC scenario.

State	Mass flow rate (kg/s)	Temperature (°C)	Pressure (bar)	Enthalpy (kJ/kg)
1	0.32	15	-	-9793.3
2	0.19	115	-	-5345.7
3	0.18	115	-	-5138.7
4	2.33	115	1.013	-13264.7
8	0.00	730	-	-5268.5
9	0.40	730	1.013	-1871.2
13	0.40	150	1.013	-2732.9
14	0.40	50	1.013	-2872.7
15	0.40	50	1.013	-2872.9
17	2.07	24	1.013	-638.6
18	2.07	108	2.000	-547.3
20	2.07	25	2.000	-637.1
21	2.07	658	2.000	-1435.4
22	2.07	577	1.216	-1532.5
23	2.07	125	1.216	-2039.4
26	2.20	115	1.013	-13264.7
27	2.20	200	1.013	-13095.7
29	0.22	15	1.013	-98.8
30	0.22	700	1.013	632.6
36	1.66	15	1.013	-98.8
37	0.00	50	1.013	-15761.7
39	0.13	115	1.013	-13264.7
40	0.13	50	1.013	-15761.7

Table A2. Flow properties at each stage of the energy system. Low gasification CC scenario.

State	Mass flow rate (kg/s)	Temperature (°C)	Pressure (bar)	Enthalpy (kJ/kg)
1	0.32	15	-	-9793.3
2	0.19	115	-	-5345.7
3	0.18	115	-	-5138.7
4	2.33	115	1.013	-13264.7
8	0.04	730	-	153.6
9	0.26	730	1.013	-3247.9
13	0.26	112	1.013	-4276.0
14	0.26	50	1.013	-4371.4
15	0.26	50	1.013	-4372.0
17	1.36	24	1.013	-917.1
18	1.36	108	2.000	-824.0
20	1.36	25	2.000	-916.3
21	1.36	558	2.000	-1800.3
22	1.36	475	1.139	-1899.4
23	1.36	125	1.139	-2295.9
26	2.20	115	1.013	-13264.7
27	2.20	200	1.013	-13095.7
29	0.11	15	1.013	-98.8
30	0.11	700	1.013	632.6
36	1.10	15	1.013	-98.8
37	0.00	50	1.013	-15761.7
39	0.13	115	1.013	-13264.7
40	0.13	50	1.013	-15761.7